



*Scale/6D® Decorative Accents™*



Criterion®

Scale/4®

Scale/6®

Scale/8®

Sonicwal®

Fabricwal®

Signature®

EchoSorb®





1935

Panelfold's founder Guy Dixon, as a teenager, begins a long career in aviation.

1950

While a pilot for Eastern Airlines in Miami, Florida, Guy patents the world's first folding door incorporating flexible panel connector hinges. This is the first of what would become hundreds of worldwide patents.

1953

Panelfold, Inc. is established in suburban Miami to produce Scale/4 wood folding doors and partitions, and franchises the first of dozens of licensed manufacturers around the world to produce Panelfold products.

1965

Panelfold introduces Sonicwal®, the world's first acoustically rated wood folding partition.

1969

Builds and moves into a new, modern 150,000 sq. ft. manufacturing facility.

1971 & 1986

Is given the E-Award by the President of the United States for excellence in exporting and the E-Star Award for continued export expansion.

1973 - 1978

Introduces Criterion®, a new, economical line of rigid vinyl folding doors to meet the needs of both public and private housing.

1987

Introduces Fabricwal® line of vinyl fabric accordion partitions.

1987 - 1991

Introduces EchoSorb® colorful, acoustical panels to absorb unwanted noise and reverberation.

2003

Panelfold enters its 50th year in the family owned and operated business, now with three generations actively engaged in the 21st century.



1953 **Panelfold®** 2004  
OVER 50 YEARS OF INNOVATIVE SPACE DIVISION SYSTEMS

**P.O. Box 680130 • Miami, FL 33168**  
**Tel.: 305/688-3501 • Fax: 305/688-0185**  
**sales@panelfold.com • www.panelfold.com**

## C O N T E N T S

### Model and Description Pages

Criterion® folding doors, the economical rigid vinyl cover up	4 and 5
Scale/4® wood folding doors, a natural choice	6 and 7
Scale/6® wood folding partitions, for rugged dependability	8 and 9
Scale/6D® wood folding doors with Decorative Accents™	10 and 11
Scale/8A® acoustical wood folding partitions to quiet down spaces	12 and 13
Sonicwal® acoustical wood accordion partitions for multi-purpose areas	14 and 15
Fabricwal® acoustical accordion partitions with soft folds of vinyl fabric	16 and 17
Fabricwal® non acoustical accordion partitions for economical sight division	18 and 19
Signature Series® wood folding doors and acoustical accordion partitions with the designers touch	20 and 21
EchoSorb® acoustical panels to absorb disturbing noise reverberation	22 and 23

Now in its fifth decade, Panelfold has long been recognized as the innovative leader in the folding door and acoustical accordion folding partition industry. Established in 1953, the company has progressed from its first small factory to a 140,000 square foot modern manufacturing facility in suburban Miami, Florida, U.S.A. and has been a major employer in Miami's multi-cultural community.

There is a Panelfold product for every budget, technical, and aesthetic consideration. We have folding doors and partitions for just about any size opening from doorways to massive room dividers and all sizes in between. And an acoustical panel is available for effective reduction of noise reverberation where there is a problem with echos.

This catalog has been crafted to give you ideas to work with to solve your space problems. Panelfold doors are made to fit your opening and not the other way around.

*Go ahead and browse the catalog or use the convenient table of contents to go directly to the model that suits your needs.*

### VHS/DVD VIDEO

In order for you to experience Panelfold's Made to your Order™ folding doors and partitions in action, you may order an applications video. Send check or money order to the address on page 2 of this brochure for \$5.00 for shipping and handling. Please specify on your check whether you want vhs or dvd. Allow two weeks for delivery. The fee will be refunded to you upon your first order. Simply mail us a copy of your store receipt after your purchase.





DOUBLE END POST DOOR IN GRAY SAND





Criterion features four inch wide, single wall, solid panels that are interconnected by rigid self-mating hinges formed as an integral part of each door. Magnetic latches and jamb moulds are standard.

CRITERION®... THE *economical*

RIGID VINYL COVER-UP!

Designed for tight budgets ...for quick installation ...for durability  
...for closets, utility rooms and room dividers.



CRITERION features single wall panels and rigid, self-mating integral hinges that travel smoothly on lifetime nylon wheels along an aluminum track.

RIGID VINYL PANEL COLOR SELECTIONS

Because the color is added before the panels are extruded, the color cannot wear off. The panels never need painting. Color selectors are available.



INSTALLATION IS QUICK AND EASY

No expensive stubbing out or heading down is required to install Criterion rigid vinyl panel folding doors. Engineered to travel smoothly on lifetime nylon wheels and so lightweight they may even be installed on existing ceilings. Simply attach the aluminum track to the ceiling or header with supplied screws. Unique concealed jamb clips are provided to clip on the deep nesting jamb mould which receives the end post latch and the jamb post which attaches the door to the permanent jamb. No exposed fasteners. Fast, neat and practical. These models are really easy to handle on the job.

Criterion® Folding Doors



SINGLE FIXED JAMB DOOR IN WOODTEX® HONEYWOOD™

Scale/4® Folding Doors



DOUBLE END POST DOOR IN HIGHTEX™ ANTIQUE ROSE

PANEFOLD SCALE/4® WOOD FOLDING DOORS save space and solve problems caused by conventional door systems. The timeless beauty and durability of wood, the wide variety of surfacing styles and colors to choose from and the narrow profile and proven performance of Scale/4® doors makes their selection a natural choice.

# a natural choice!

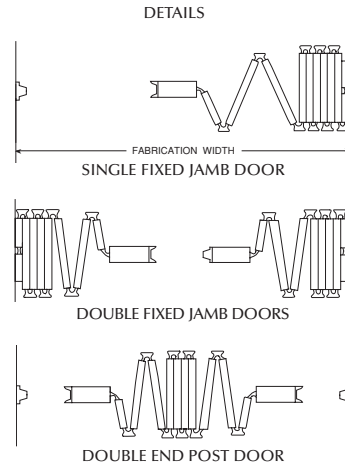

All Scale/4® Folding Doors are supplied complete with end posts and lockable touch-bar automatic latches, handles and jamb mould, wheels, aluminum track and all installing hardware including illustrated, easy to follow installation instructions. Both standard sizes and custom sizes to fit irregular openings are available.

#### SURFACES AND FINISHES

Panefold machine laminates all the popular surfaces illustrated below for Scale/4® folding door models. Selectors are available.

DUAL WALLED MEMORY-ACTION® VINYL HINGES Vinyl hinges join, seal and protect Scale/4® panel edges from marring scrapes and blows. A hinge color selector is available.



#### STARTEX™ TEXTURED VINYL



#### WOODTEX® WOOD GRAIN VINYL

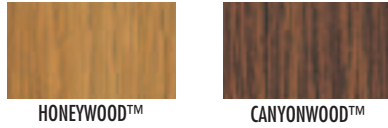
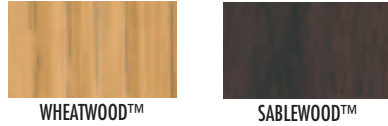

#### FABRICTEX® FABRIC TEXTURED VINYL

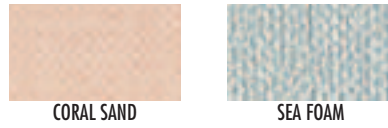

#### HIGHTEX™ Textured Vinyls



#### SANDTEX™ MULTICOLOR VINYL

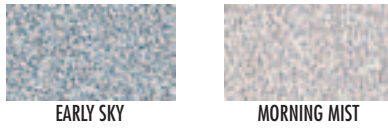

#### ROPETEX® ROPE TEXTURED VINYL



#### WOOD VENEERS



#### WILSON ART® OR FORMICA® HIGH PRESSURE LAMINATES\*

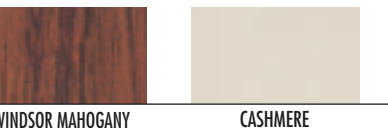
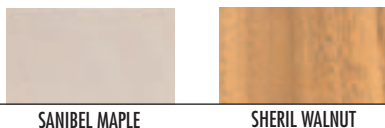

[www.panefold.com](http://www.panefold.com)

\*The above are random samples of the wide selection of solid colors, woodgrains and patterns that are available. See manufacturer's selector cards for the complete line.

Scale/4® Folding Doors





DOUBLE FIXED JAMB PARTITIONS IN FROSTED ASH

SINGLE FIXED JAMB PARTITION IN FORMICA® CELADON GLAZE



*Scale/6® Folding Partitions*



Panelfold Scale/6® wood folding partitions with solid panels divide spaces economically. A wide variety of surfacing styles and colors may be selected to enhance the durability and timelessness of the Scale/6® wood construction. The proven performance and clean, simple design of Scale/6® partitions assure rugged dependability.

# rugged dependability!

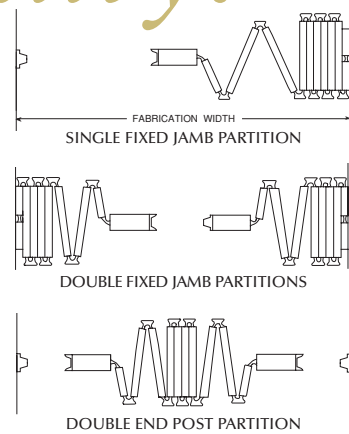

ALL SCALE/6® FOLDING PARTITIONS are supplied complete with end posts and lockable touch-bar automatic latches, handles and jamb mould, ball-bearing wheels, aluminum track and all installing hardware including illustrated, easy to follow installation instructions. Custom sizes to fit irregular openings are available.

## SURFACES AND FINISHES

Panelfold machine laminates all the popular surfaces illustrated below for Scale/6® folding partitions models. Selectors are available.

DUAL WALLED MEMORY-ACTION® VINYL HINGES Vinyl hinges join, seal and protect Scale/6® panel edges from marring scrapes and blows. A hinge color selector is available.



### STARTEX™ TEXTURED VINYL



### WOODTEX® WOOD GRAIN VINYL

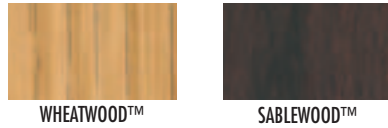

### FABRICTEX® FABRIC TEXTURED VINYL

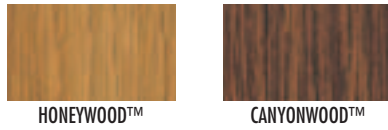

### HIGHTEX™ Textured Vinyl



### SANDTEX™ MULTICOLOR VINYL



### ROPETEX® ROPE TEXTURED VINYL

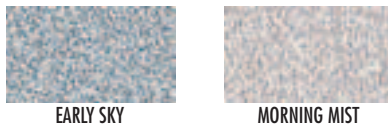

### WOOD VENEERS



### WILSON ART® OR FORMICA® HIGH PRESSURE LAMINATES\*



[www.panelfold.com](http://www.panelfold.com)

\*The above are random samples of the wide selection of solid colors, woodgrains and patterns that are available. See manufacturer's selector cards for the complete line.

Scale/6® Folding Partitions



DOUBLE FIXED JAMB CARVEDOR® IN AMERICAN WALNUT

DOUBLE FIXED JAMB GLAZEDOR® IN WOODTEX®  
WHEATWOOD WITH CLEAR TRANSLUCENT INSERTS

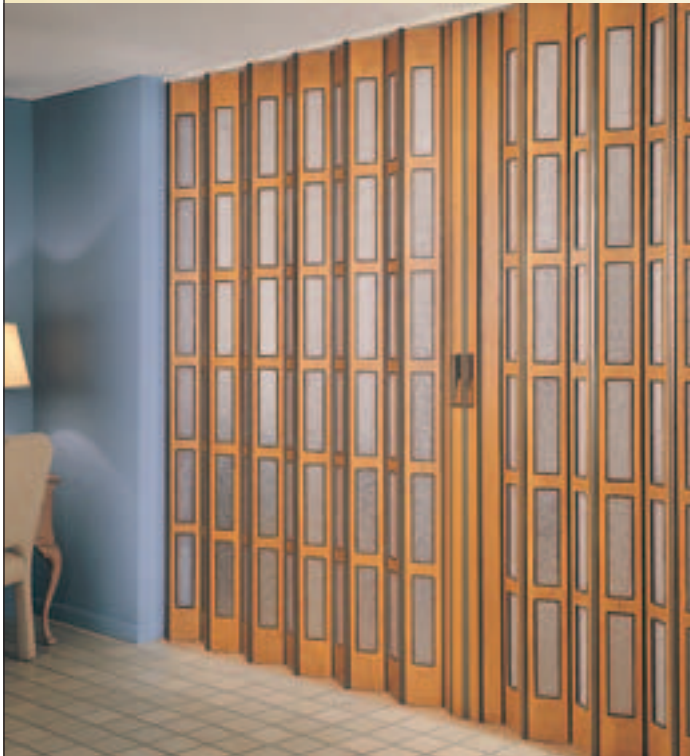

DOUBLE FIXED JAMB MIRRODOR™ IN AMERICAN WALNUT



JOINING CANEDORS® IN RED OAK WOOD VENEER





# decorative accents

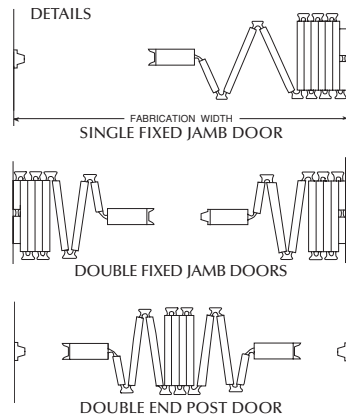

All Scale/6® Folding Doors are supplied complete with end posts and lockable touch-bar automatic latches, handles and jamb mould, ball-bearing wheels, aluminum track and all installing hardware including illustrated, easy to follow installation instructions. Custom sizes to fit irregular openings are available

## DECORATIVE PANEL OPTIONS

Scale/6® Decorative Accents™ is offered in the popular surfaces illustrated below. Selectors are available.

FOLDING DOORS WITH THE DESIGNER TOUCH... CARVED panel detailing, natural cane, translucent, transparent or mirror inserts dramatically accent closets, doorways and room divisions, in addition to saving space more effectively than conventional doors.

<p>CARVED</p> <p>Red Oak      Walnut</p>		<p>CANED</p> <p>Open      Closed</p>		<p>TRANSLUCENT</p> <p>Clear      Amber</p>		<p>Memory Action VINYL HINGE</p> <p>Selectors are available.</p>
--	--	--------------------------------------	--	--	--	--

<p>STARTEX™ TEXTURED VINYL</p> <p>WHITE      WAX</p>		<p>WOODTEX® WOOD GRAIN VINYL</p> <p>WHEATWOOD™      SABLEWOOD™</p>		<p>FABRICTEX® FABRIC TEXTURED VINYL</p> <p>DOVER      PEARL</p>	
--	--	--	--	---	--

<p>ROSE MIST      OYSTER</p>		<p>HONEYWOOD™      CANYONWOOD™</p>		<p>CORAL SAND      SEA FOAM</p>	
------------------------------	--	------------------------------------	--	---------------------------------	--

<p>HIGHTEX™ Textured Vinyls</p> <p>CLOUD      FAWN</p>		<p>SANDTEX™ MULTICOLOR VINYL</p> <p>OYSTER      GREIGE</p>		<p>ROPETEX® ROPE TEXTURED VINYL</p> <p>SNOW DRIFT      FROSTY</p>	
--	--	--	--	---	--

<p>ROSE      CEMENT</p>		<p>EARLY SKY      MORNING MIST</p>		<p>TAUPE      CLOUD</p>	
-------------------------	--	------------------------------------	--	-------------------------	--

<p>WOOD VENEERS</p>					
<p>WHITE ASH      NATURAL BIRCH</p>		<p>RED OAK      WHITE MAPLE</p>		<p>FROSTED ASH      AMERICAN WALNUT</p>	

<p>WILSON ART® OR FORMICA® HIGH PRESSURE LAMINATES*</p>					
<p>SANIBEL MAPLE      SHERIL WALNUT</p>		<p>WINDSOR MAHOGANY      CASHMERE</p>		<p>STORM NEBULA</p>	



Scale/6® Decorative Accents™ Folding Doors

\*The above are random samples of the wide selection of solid colors, woodgrains and patterns that are available. See manufacturer's selector cards for the complete line.

*Scale/8® Acoustical Folding Partitions*



CURVED FOLDING PARTITION IN HIGHTEX® CLOUD



# SCALE/8® ACOUSTICAL FOLDING PARTITIONS • STC 25

Panelfold single panel Scale/8® acoustical partitions are affordable, good looking alternatives to ordinary accordion partitions. Available with a laboratory Sound Transmission Class of STC 25 and a broad selection of surfacing styles and colors. Scale/8® quiets down spaces, effectively and elegantly.

**QUALITY CONSTRUCTION**  
SCALE/8® single panel models share many of the quality construction features of Sonicwal® accordion models including laminated panel surfaces, bronze ESP or natural anodized finish deep nesting end posts and Memory-Action dual wall vinyl hinges.

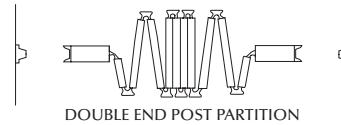
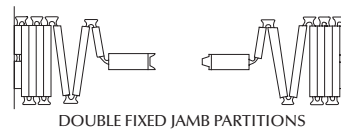
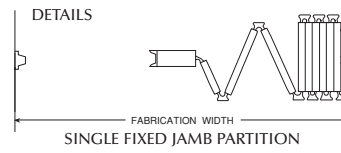

**Acoustical Treatment**  
Scale/8® achieves STC 25 by adding Sonic-sweep seals top and bottom, Ceilingguard head trim, dual-row end posts sound seals. Positive latches and Panelfold's exclusive Trakseal™ track closure device. Trakseal stops unwanted sound from entering the void of the overhead track and exiting to the next room.

## SURFACES AND FINISHES

Panelfold machine laminates all the popular surfaces illustrated below for Scale/8® folding partitions models. Selectors are available.

**DUAL WALLED MEMORY-ACTION® VINYL HINGES**  
Vinyl hinges join, seal and protect Scale/8® panel edges from marring scrapes and blows. A hinge color selector is available.



### STARTEX™ TEXTURED VINYL



WHITE

WAX



ROSE MIST



OYSTER

### WOODTEX® WOOD GRAIN VINYL



WHEATWOOD™

SABLEWOOD™



HONEYWOOD™



CANYONWOOD™

### FABRICTEX® FABRIC TEXTURED VINYL



DOVER

PEARL



CORAL SAND



SEA FOAM

### HIGHTEX™ Textured Vinyls



CLOUD

FAWN



ROSE



CEMENT

### SANDTEX™ MULTICOLOR VINYL



OYSTER

GREIGE



EARLY SKY



MORNING MIST

### ROPETEX® ROPE TEXTURED VINYL



SNOW DRIFT

FROSTY



TAUPE



CLOUD

### WOOD VENEERS



WHITE ASH

NATURAL BIRCH



RED OAK



WHITE MAPLE



FROSTED ASH



AMERICAN WALNUT

### WILSON ART® OR FORMICA® HIGH PRESSURE LAMINATES\*



SANIBEL MAPLE

SHERIL WALNUT

WINDSOR MAHOGANY

CASHMERE

STORM NEBULA



[www.panelfold.com](http://www.panelfold.com)

\*The above are random samples of the wide selection of solid colors, woodgrains and patterns that are available. See manufacturer's selector cards for the complete line.

Scale/8® Acoustical Folding Partitions



SINGLE FIXED JAMB PARTITION IN CARVED AMERICAN WALNUT

DOUBLE FIXED JAMB PARTITION IN WOODTEX® HONEYWOOD



DOUBLE FIXED JAMB PARTITIONS IN RED OAK



SINGLE FIXED JAMB PARTITION IN WILSON ART® CASHMERE



# Sonicwal® Acoustical Accordion Partitions • STC 42

Sonicwal® is the acoustical accordion partition that has evolved through Panelfold's commitment to excellence and understanding of multiple use areas. Sonicwal's functional aesthetics and visual harmony offer solutions for hospitality, corporate, civic, medical, religious and educational facilities.

## SONICWAL CONSTRUCTION FEATURES

- Many decorative surfaces machine laminated to twin walls of strong, stable high density particleboard panels that are more resistant to wear and tear than the covers on ordinary partitions.
- Deep-nesting end post has dual vertical sound seals, Gripull handles and a positive latch for laboratory rated sound control.
- Six large ball-bearing wheels on each end post support and guide the operation of these models smoothly.



- Four large ball-bearing wheels are installed on each 16 gauge steel support bracket assembly at each volute. There are no unsupported volutes.
- Low profile extruded aluminum track top supports the partition and provides quiet, efficient operation.
- Three-fingered Sonicsweep™ seals are field adjustable during installation for an effective seal at top and bottom of the partition. Perfect for irregular floors.

## SURFACES AND FINISHES

Panelfold machine laminates all the popular surfaces illustrated below for Sonicwal® accordion partitions models. Selectors are available.

DUAL WALLED MEMORY-ACTION® VINYL HINGES  
Vinyl hinges join, seal and protect Sonicwal accordion partitions edges from marring scrapes and blows. A hinge color selector is available.



### STARTEX™ TEXTURED VINYL



WHITE

WAX



ROSE MIST

OYSTER

### WOODTEX® WOOD GRAIN VINYL



WHEATWOOD™

SABLEWOOD™

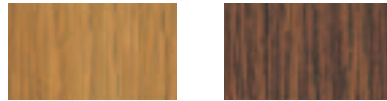

HONEYWOOD™

CANYONWOOD™

### FABRICTEX® FABRIC TEXTURED VINYL



DOVER

PEARL



CORAL SAND

SEA FOAM

### HIGHTEX™ Textured Vinyls



CLOUD

FAWN



ROSE

CEMENT

### SANDTEX™ MULTICOLOR VINYL



OYSTER

GREIGE



EARLY SKY

MORNING MIST

### ROPETEX® ROPE TEXTURED VINYL



SNOW DRIFT

FROSTY



TAUPE

CLOUD

### WOOD VENEERS



WHITE ASH

NATURAL BIRCH



RED OAK

WHITE MAPLE



FROSTED ASH

AMERICAN WALNUT

### WILSON ART® OR FORMICA® HIGH PRESSURE LAMINATES\*



SANIBEL MAPLE

SHERIL WALNUT



WINDSOR MAHOGANY

CASHMERE



STORM NEBULA



www.panelfold.com

\*The above are random samples of the wide selection of solid colors, woodgrains and patterns that are available. See manufacturer's selector cards for the complete line.

Sonicwal® Acoustical Accordion Partitions

*Fabricwal® Acoustical Accordion Partitions*



SINGLE FIXED JAMB PARTITION IN SANDTEX™ MORNING MIST

SINGLE FIXED JAMB PARTITION IN HIGHTEX™ ANTIQUE ROSE





AIR RELEASE FABRICWAL end posts are equipped with air release vents that allow air trapped during the operation of the partition to help keep fabric covers from “ballooning” and to allow easier operation. Gripull handles and positive latches are standard on all models.



BEAUTIFUL SOFT FOLDS OF UP-TO-DATE, COLORFUL, heavy duty wall coverings backed by steel panels and acoustical liners and supported by welded steel, pantograph hinge frame work, divide spaces and efficiently control sound. Large ball-bearing wheels assure ease of operation and a lifetime of service.



### TYPES OF APPLICATIONS

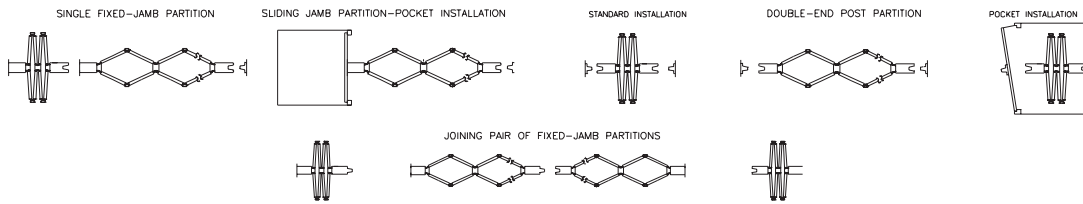

## *finishes*

STANDARD PANELFOLD FABRICWAL PARTITIONS are manufactured in heavy-duty vinyl fabrics illustrated. Selectors are available. Optional wall carpet and panel fabrics are also available.

#### ROPETEX® ROPE TEXTURED VINYL



#### HIGHTEX™ HIGH TEXTURED VINYL



#### FABRICTEX® FABRIC TEXTURED VINYL

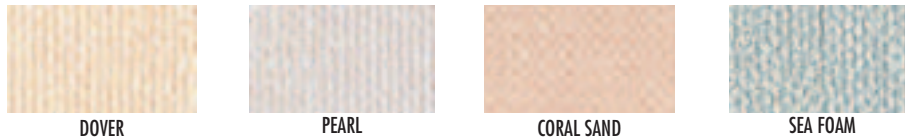

#### SANDTEX™ MULTICOLOR VINYL

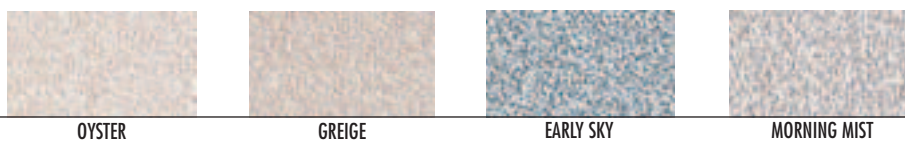

Fabricwal® Acoustical Accordion Partitions

*Fabricwal® Non Acoustical Accordion Partitions*



SINGLE FIXED JAMB PARTITION IN FABRICTEX® SEA FOAM



FUNCTIONAL *elegance*

**FABRICWAL® NON-ACOUSTICAL ACCORDION PARTITIONS**

Beautiful soft folds of up-to-date, colorful, heavy duty coverings, supported by a welded steel, pantograph hinge frame work, sight-divide spaces luxuriously. Fabricwal's quiet, easy operation and uniform, compact profile utilizes space with grace and ease.

**Air Release Fabricwal**

end posts are equipped with air release vents that allow air trapped during the operation of the partition to help keep fabric covers from "ballooning" and to allow easier operation. Gripull handles and positive latches are standard on all models.



**TYPES OF APPLICATIONS**

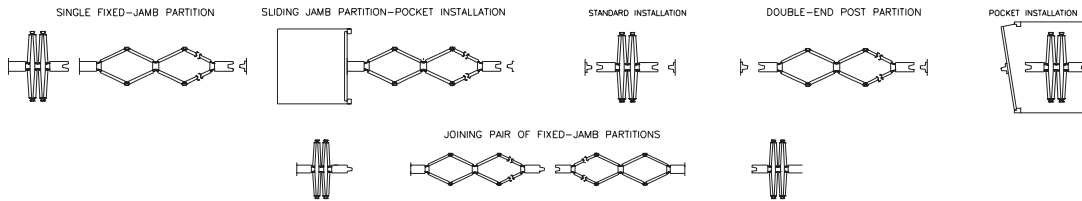

**FINISHES**

Standard Panelfold Fabricwal partitions are manufactured in heavy-duty vinyl fabrics illustrated below. Selectors are available. Optional wall carpet and panel fabrics are also available.

**ROPETEX® ROPE TEXTURED VINYL**



**HIGHTEX™ HIGH TEXTURED VINYL**



**FABRICTEX® FABRIC TEXTURED VINYL**



**SANDTEX™ MULTICOLOR VINYL**

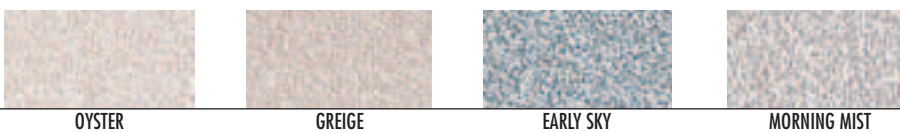

Fabricwal® Non Acoustical Accordion Partitions



DOUBLE FIXED JAMB DOORS IN RED OAK WITH ECHOSORB® ACOUSTICAL PANELS



*Signature® Series Folding Doors*



# folding doors

PANELFOLD SIGNATURE® SERIES WOOD FOLDING DOORS and acoustical partitions close off irregular sized openings up to 8'1" high quickly, beautifully, easily. Featuring panels and shaped matching wood panel connector mouldings, Signature® Series blends with traditional or contemporary decor.



Single panel and twin panel acoustical models have top aluminum track. All Signature® Series models are supplied complete with end posts and Touch-Bar™ automatic latches, (optional cylinder lock, privacy lock and/or emergency coin slot release) handles and jamb mould and all installing hardware including illustrated, easy to follow installation instructions. Acoustical models have top and bottom adjustable sweep seals.

Two Signature® models are available: Single panel models provide sight privacy and twin panel acoustical models are designed for both sight and sound privacy.



Machine laminated wood panels, connected with matching wood mouldings of the same material are available in the following fine selections of finishes. Wood veneers are regularly available in factory applied clear lacquer or can be ordered unfinished for field finish applications. Factory stained custom finished may be ordered to match your furnished sample.

## TYPES OF APPLICATIONS

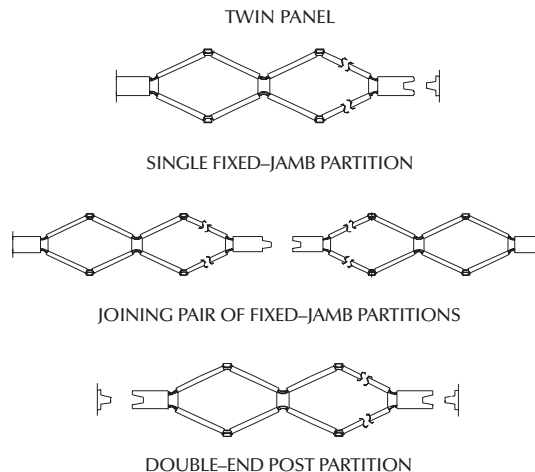
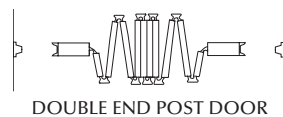
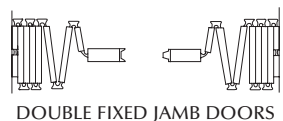
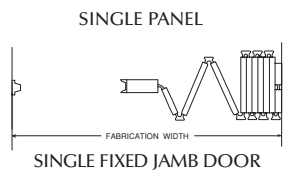

## WOOD PANELS AND MATCHING PANEL CONNECTOR MOULDINGS

WOOD VENEER

WOODTEX® VINYL



WHITE MAPLE

FROSTED ASH

WHITE ASH

RED OAK

WHEAT WOOD™

HONEY WOOD™

Signature® Series Folding Doors

# *acoustical panels*

## FEATURES

- Colorful, acoustically transparent panel fabric
- N.R.C.\* .75 per ASTM 423  
\*Noise Reduction Coefficient
- Standard size 24" x 24" or 24" x 48" x 1 1/4" and custom sized panels up to 48" x 96" can be made to your order™
- 3 pcf (lbs per cubic foot) density Fiberglas® insulation, MDF backer board, and aluminum frame



CEILING SUSPENDED PANELS



## APPLICATIONS

- School gymnasiums / multi-purpose rooms
- Music rooms
- Auditoriums
- Home theaters
- Large halls

WALL MOUNTED PANELS



## The EchoSorb® Solution

### WHY SHOULD YOU USE ECHOSORB® ACOUSTICAL PANELS?

In rooms with hard walls, floors and windows, do you feel like you are in an echo chamber? After spending large amounts on state-of-the-art equipment to get great audio performance, are you disappointed with the results? EchoSorb® acoustical panels will modify the affect that these hard surfaces have on the sound in your room by absorbing the echos. You can “tune” your room acoustically to your needs.

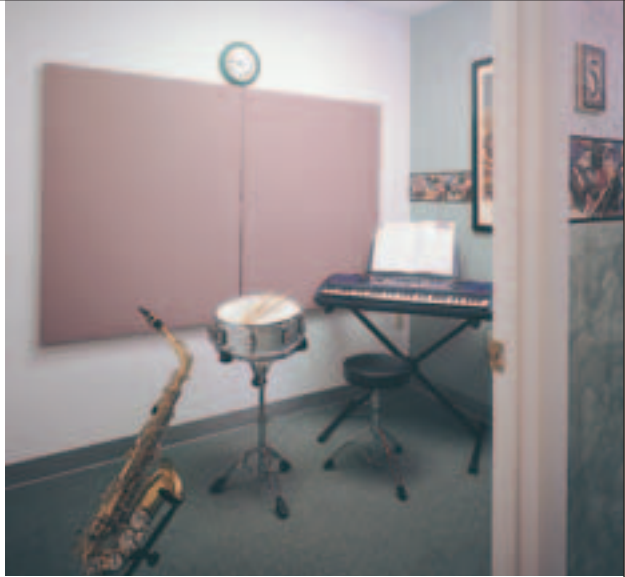

### ECHOSORB® PANEL CONSTRUCTION.

EchoSorb® acoustical panels are framed in heavy duty extruded aluminum and backed with MDF (Medium Density Fiberboard). The panels make effective use of the acoustical glass fiber insulation behind the panel fabric.

The fabric is wrapped and stapled to the back of the panel with tailored corners.

*acoustical performance*

EchoSorb® noise absorbing panels provide control of the echo effect. They are designed to deaden sound “bounce” within the room.

### WALL MOUNTED PANELS

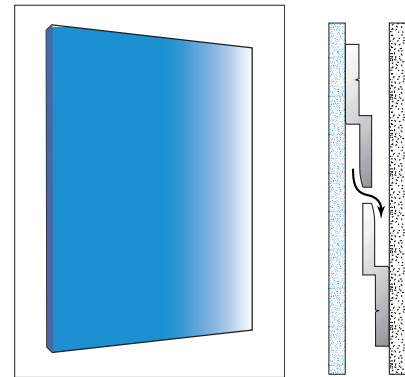

Echosorb® acoustical panels may be wall mounted with aluminum “Z” brackets. The panels easily lock right in place and may be quickly removed or relocated. Also panels may be installed using Velcro® Industrial Strength Sticky Back® tape.

### ECHOTEX™ STANDARD COLORS

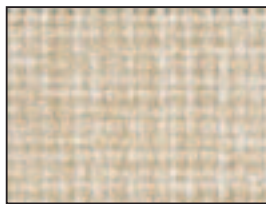

SANDSTONE



SILVER SHORES



SILVERLY MOONLIGHT



WILTON BLUE

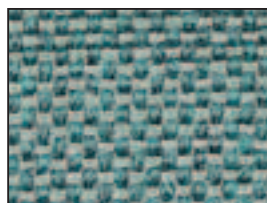

GREEN BLUE SLATE

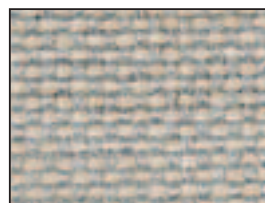

CLAM SHELL

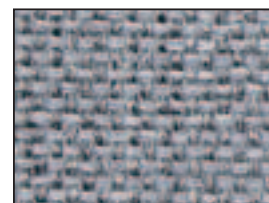

ABSTRACT GREY

*EchoSorb® Acoustical Panels*



**Panelfold**<sup>®</sup>  
*Made to your Order*<sup>™</sup>

Panelfold is constantly developing its products and reserves the right to change specifications or materials without notice.  
All rights reserved. Form No. 5A430A. Printed in U.S.A.